

HEAVY DUTY.

IT'S IN THE NAME.
IT'S IN THE PRODUCT.



**SEAMLESS
TUBE.**

**ONE-PIECE BEAM.
(NO WELDED SPINDLES)**

**EXTRA MATERIAL AT
BEARING JOURNALS.**

AXN TRAILER AXLES

TRAILER AXLE KEY FEATURES

- ▶ Complete line of axles in stock and ready to ship
- ▶ Your Axle, Your Way:
 - Fully-assembled
 - Beam & Brake
- ▶ Custom tracks also available!
- ▶ Container load direct ship options!
- ▶ Industry standard replacement parts
- ▶ 5-year standard warranty



▶ AXN 16.5" Brake Axle



▶ AXN 12.25" Brake Low Boy Axle



▶ AXN Drop Center Axle



▶ AXN Crank/Full-drop Axle



▶ AXN Disc Brake Trailer Axle with Wabco Pan 22

AXN TRAILER AXLE NOMENCLATURE

Product	Nominal Beam Rating	Spindle Type	Brake Size (in.)	Brake Type	Track (in.)
TA Trailer Axle	200 20.0K lbs	T Tapered	67 16.5 x 7	E Extended Service	715 71.5"
TAC Trailer Axle Crank	225 22.5K lbs	P Parallel	27 12.25 x 7.5	S Standard Service	775 77.5" Custom Tracks also available.
TAD Trailer Axle Drop Center	250 25.0K lbs		68 16.5 x 8	D Disc	
	300 30.0K lbs		69 16.5 x 8.625		
			W2 Wabco Pan 22		

AXN SUSPENSION SYSTEMS

MECHANICAL SUSPENSION KEY FEATURES

- ▶ Reliable, proven design
- ▶ High-strength material for longer life
- ▶ Simple maintenance
- ▶ Available in single and multiple axle configurations
- ▶ Industry Competitive Warranty
- ▶ Available in underslung and overslung configurations
- ▶ Various spring seat heights allow for a wide range of ride height solutions
- ▶ Available with under-, straddle-, or flange-mount hangers

UNDERSLUNG TMN448BL007S model shown.



OVERSLUNG TMN448BT007S model shown.



HIGHLIGHTS & BENEFITS

✓ Fabricated Front, Center & Rear Hangers (Under-mount shown)

- A** E-coated for corrosion resistance
- B** Drain holes on sides and low points on spring seat help prevent corrosion
- C** Grade 8 torque arm fasteners with reinforced mounting flanges
- D** Industry standard Grade 8 capscrew & nut style pivot bolt for ease of maintenance

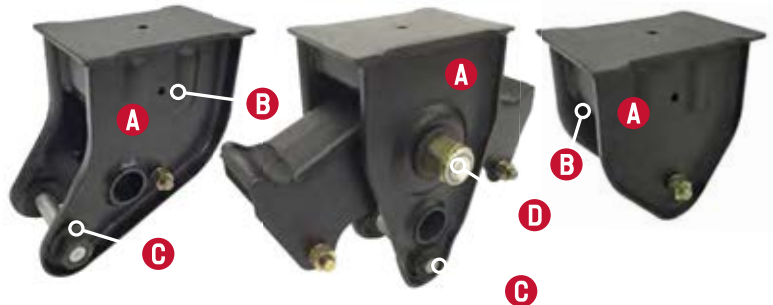

THE EVOLUTION OF QUALITY, ENGINEERING & MANUFACTURE

1997

- ▶ FUWA was founded in 1997, beginning with the manufacturing of trailer axles and landing gears. The factory was located in Shunde, China.
- ▶ FUWA Singapore was established.



1998

- ▶ FUWA developed a patented "single-piece" axle beam with heat formed spindles. This unique "single-piece" design offered significant improvements in durability and longevity.
- ▶ Obtained the certificate for ISO9001.



1999

- ▶ One-piece axles gained widespread acceptance in China and Asia, which allowed growth. The daily production of trailer axles was increased to 300 pieces.



2000

- ▶ FUWA trailer axles reach more than 70% of the Chinese market.
- ▶ FUWA products export to 36 countries and regions worldwide.



2001

- ▶ FUWA K-Hitch (Australia) was established.
- ▶ FUWA began manufacturing fifth-wheels. In April, FUWA fifth-wheels pass all necessary tests for the Australian market.

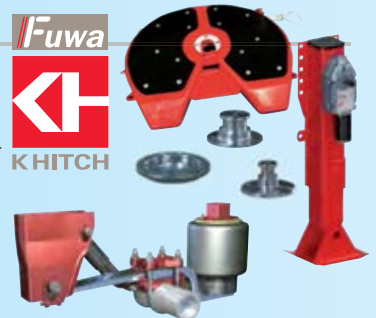

2002

- ▶ FUWA as a product and b...

2003

- ▶ A new trailer was of 80 of pr build annu capa to 65

AXN SUSPENSION SYSTEMS

NEW FOR 2016! INTEGRATED AND U-BOLT AIR SUSPENSIONS

- ▶ Full range of ride heights with multiple axle configurations
- ▶ Eccentric Alignment System – No Welding Required!
- ▶ Multi-function Bushing

- ▶ C-Channel Frame Rails with Integrated Hangers
- ▶ Available with 1-3/8 and 1-5/8 diameter pins and standard spacings
- ▶ Available Dock-height Hold Mechanism
- ▶ Full range of ride heights

- ▶ Multiple axle configurations
- ▶ Pin-pull mechanism available in manual or air-release
- ▶ Eccentric Alignment System – No Welding Required!
- ▶ Multi-function Bushing



Contact your AXN Regional Sales Manager to hear about our NEW Air Suspension product offerings!

MODULAR AIR RIDES VOCATIONAL AND SLIDING TANDEM

- ▶ Patented Bolt-on® Clamp Group and Formed Retention Grooves on Axle (not machined grooves)
- ▶ Spring Steel Trailing Arm with High Density Steel/Rubber/Steel Bushing
- ▶ Center Mounted Shock Absorbers
- ▶ Industry Competitive Warranty
- ▶ NEW: Bolt-on Axle lift on MARS23

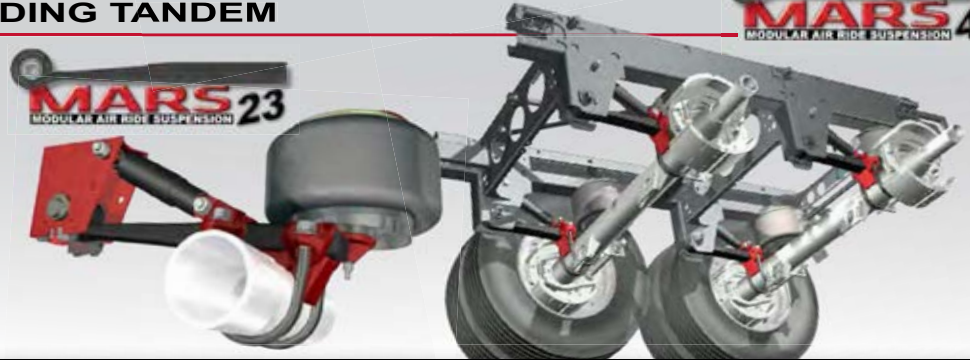

RING

2003

AXN was established as a joint venture company for the production of slack adjusters and brake chambers.



2004

A new 120,000 m² axle plant built consisting of 10,000 m² production buildings. The annual production capacity increased to 50,000 axles.

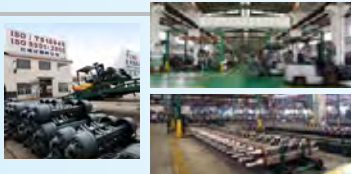

2005

- ▶ FUWA started producing brake linings for trailer axles.



2006

- ▶ FUWA begins supplying many leading North American axle and suspension companies under a private label arrangement.

2007

- ▶ Annual sales reach 600,000 trailer axles and 120,000 pairs of landing gears. FUWA becomes the world's largest trailer axle manufacturer.



2008

- ▶ FUWA partnered with MCB and developed a new range of European trailer axles branded "Valx."
- ▶ In order to meet growing demand from China and Worldwide markets, FUWA begins planning to set up a new world-class plant in Taishan City, China.



2009

- ▶ Upgraded the quality system from ISO9001 to ISO/TS16949.
- ▶ Established a joint venture company with WABCO for the production of disc brake calipers.
- ▶ Became shareholders of CIMC Huajun Casting Company and Guangjin Castings & Forging Foundry Co., Ltd.
- ▶ Expanded into the business of drive axles and front steering axles for trucks and buses.



▶ AXN Heavy (FUWA US)

AXN LANDING GEAR

PRO50 & PRO60 LANDING GEAR FEATURES

- ▶ Robotic welding with fully-wrapped reinforcement collar around upper leg tubing for greater stability against lateral forces
 - ▶ Drop forged gears from quality steel, hardened and machined to extend service life and provide easy winding and lifting.
- High Ratio:**
3.3 turns/inch of travel
- Low Ratio:**
25.4 turns/inch of travel
- ▶ High performance E-coating with zinc-phosphate pre-treatment provides superior resistance to severe weather conditions

PRO50 model shown.



PRO60 model shown.

NEW FOR 2016!

by Razor International Pty. Ltd.

eLEG

Electronic Motorized Landing Gear. Raise or Lower at the touch of a button!
Same great features as our PRO60, plus:

- ▶ Easy to understand, two-speed, push button operation
- ▶ Robust, low-profile aluminium gearbox casing
- ▶ Heavy duty electric motor and state-of-the-art electronics
- ▶ Independent power supply via maintenance-free battery, includes built-in protections and trickle charger
- ▶ Manual override capability
- ▶ Maintenance free Power Drive Gearbox



HEAVY LIFT
(Under Load, 60,000 lb. rating)



NEUTRAL



FAST SPEED
(Brings Gear Up or Down Quickly)

eLeg BENEFITS

- ✓ No more manual cranking
- ✓ Reduces operator back strain
- ✓ Saves time

✓ **LET eLEG DO THE HARD WORK!**

ASSEMBLY, KITTING OR DIRECT SHIP



WE DELIVER YOUR PRODUCT "YOUR WAY"

- ▶ AXN's Louisville, Kentucky Assembly & Distribution Center has a Dressed Axle assembly line with a Continuous Improvement QC System
- ▶ Over 93,000 sq.-ft. of warehouse space
- ▶ Mechanical Suspension Kitting available
- ▶ Truckload or LTL from Louisville
- ▶ Container Direct Ship from the manufacturer



✓ **YOUR CONTAINER, YOUR WAY, DIRECT!**

MIX & MATCH TRAILER KITS:
Suspensions, Axles, Landing Gear or all Three!

2010

- ▶ Taishan City Plant completed, with an area of 1.6 million square meters and 12 production buildings. The plant is characterized by world-class production, testing, quality assurance and state-of-the-art equipment.



2011

- ▶ Manufacturing begins for Agricultural axles and suspension systems.
- ▶ FUWA begins production of off-road axles.



2012

- ▶ Construction of the new Shunde Plant begins, which covers an area of 800,000 square meters.
- ▶ The Guangjin Foundry was officially renamed Guangdong Fuwa Casting & Forging Co., Ltd. with an annual cast steel and cast iron production capacity reaching 600,000 tons.
- ▶ State-of-the-art, fully automated, high-speed static pressure production line for off-highway axle components with flask dimensions of 2500mm x 900mm x 750mm.

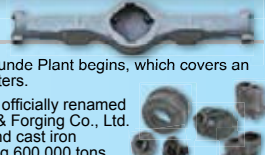

2013

- ▶ Construction of the new Shunde Plant and Guangjin Foundry completed.



2014

- ▶ Fuwa K-Hitch Australia Pty. Ltd. acquires VALX on November 1, 2014.



2015

- ▶ eLeg Landing Leg launched
- ▶ Cast 5th Wheel
- ▶ Commercial Vehicle Systems expansion in Asia and Europe



▶ Fuwa Heshan Industrial Park launched

AXN HEADQUARTERS & REGIONS



HEADQUARTERS

5534 National Turnpike
Louisville, KY 40214 • USA
502.749.3200
www.AXNHeavyDuty.com

REGIONAL SALES MANAGERS

USA West & Western Canada Region:
Dustin Garza; dgarza@axnheavyduty.com
North Central Region:
Paul Coplen; pcoplen@axnheavyduty.com
South Central Region:
Paul Coplen; pcoplen@axnheavyduty.com
Northeast Region:
Rich Gaulrapp; rgaulrapp@axnheavyduty.com



Southeast Region:
David Dorsey; ddorsey@axnheavyduty.com
Eastern Canada Region:
John Logan; jlogan@axnheavyduty.com

FUWA GROUP COMPANIES



- ▶ FUWA trailer axles reach more than 80% of the Chinese market.
- ▶ FUWA products export to 40+ countries and regions worldwide.



CHINA

FUWA ENGINEERING MANUFACTURING CO., LTD.
▶ Shunde, Foshan, Guangdong Province
FUWA HEAVY INDUSTRIES CO., LTD.
▶ Taishan, Jiangmen, Guangdong Province
FUWA INDUSTRIAL PARK
▶ Heshan, Jiangmen, Guangdong Province
F1 TRANSPORT ENGINEERING CO., LTD.
▶ Shunde, Foshan, Guangdong Province
FUWA CASTING & FORGING CO., LTD.
▶ Shunde, Guangdong Province

FUWA LEAF SPRING CO., LTD.
▶ Shunde, Foshan, Guangdong Province
WABCO FUWA AUTO BRAKING SYSTEM CO., LTD.
▶ Taishan, Jiangmen, Guangdong Province
LELIU WHARF & CONTAINER CO., LTD.
▶ Shunde, Foshan, Guangdong Province
GONGYI PORT CO., LTD.
▶ Taishan, Jiangmen, Guangdong Province
FUWA ENGINEERING (S) PTE LTD.
▶ Singapore, Malaysia

AUSTRALIA

FUWA K HITCH PTY LTD
▶ Melbourne, Victoria
▶ Perth, Western Australia
▶ Brisbane, Queensland

EUROPE

VALX B.V
▶ Valkenswaard, Netherlands

NORTH AMERICA

AXN HEAVY DUTY, LLC
▶ Louisville, Kentucky